

Long-Distance Agreement in Tsez: A Reappraisal

PRITHA CHANDRA

Abstract

This paper is a critique of Agree-based accounts of long-distance agreement in Tsez. It highlights the inconsistencies inherent in such analyses and suggests instead an alternative where agreement is accomplished in ‘local’ configurations brought forth by the structure-building operation Merge and Move/Remerge. Contra what has been proposed before, the paper suggests that the agreement triggering nominal has an uninterpretable structural Case feature checked as a reflex of phi-feature checking with the matrix verb.

Introduction

Tsez, a Nakh-Dakhestanian language spoken in the northeast Caucasus presents an intriguing example of phi-feature agreement on verbal heads triggered by nominals across (apparently) finite clauses.¹ Recent studies (cf. Bhatt, 2005; Polinsky and Potsdam, 2001) try to incorporate the phenomenon within Chomsky’s (2000, 2001a, b) long-distance Agree based paradigm, wherein agreement is realized without inducing movement of the trigger to the probe’s ‘checking domain’ (in the sense of Chomsky, 1993). This paper exposes some crucial problems in these studies and suggests a ‘local’ alternative. The core assumption of my analysis is that the agreement triggering (absolutive) nominal adjoins to the embedded TP, which in turn pied-pipes to the specifier of matrix v. By virtue of being adjoined to the moved phrase – the element is also within the ‘checking domain’ of the matrix verb (also see Frank, 2005; Koopman, 2003). However, this paper provides another independent solution, which rationalizes the idea that elements adjoined to specifiers – at least in some instances – may trigger agreement with the respective head. I argue that adjunction to TP is a step of agnostic movement (Boskovic, 2002; Franks and Lavine, 2006) of the absolutive in an attempt to remain as close to v as another potential goal, the TP itself. Despite this step of movement, the TP – being the closest goal – moves and merges with v. The absolutive subsequently reprojects (à la Hornstein and Uriagereka, 2002).² This makes the adjoined element sister to the target. ‘Long-distance-agreement’ between v and the reprojected DP thereby ensues in a ‘local’ configuration. My analysis also provides some evidence calling for a stricter alliance between case and agreement checking. I maintain that absolutive case on

¹ I say ‘apparently’ because these clauses cannot take overt complementizers (more on this below).

² For more elaborate discussion on the constraints on reprojection and effects on linearization and scope, see Chandra (2006).

the agreement trigger is a reflex of phi-feature checking between it and the matrix verb. By doing this, I uphold Chomsky's (2000, 2001a, b) claim that structural case on a nominal is its way of remaining visible to the computational system.

The discussion is thus organized. I start with an exposition of the long-distance agreement (LDA) patterns in Tsez. This is followed by a summary of an Agree-based analysis (Polinsky and Potsdam, 2001). An alternative analysis is proposed in section 3, while section 4 accounts for the intervention effects observed with Tsez LDA. Section 5 is the conclusion.³

1 Tsez: The Facts

Tsez is a predominantly agglutinating, morphologically ergative language. Subjects of transitives bear ergative case, whereas intransitive subjects and transitive objects are case-valued absolutive.⁴ Consider:

- (1) *ziya* *b-ik'i-s*.
cow.III.abs. III-go-pst.evid
 'The cow left'
- (2) *eniy-a* *ziya* *b-iser-si*.
mother-erg. cow.III.abs. III-feed-pst.evid
 'The mother fed the cow'

Verbal agreement is manifested in terms of (four) noun-classes with singular and plural variations. The agreement trigger could be either the subject or the object, as illustrated in (1) and (2) respectively. Other than these cases of intra-clausal agreement, Tsez also allows cross-clausal agreement, as shown below:

- (3) *eni-r* [*uzi* ϕ -*ay-ru-li*] ϕ -*iy-xo*.
mother-dat. [boy.I.abs. I-arrive-pstprt.nmlz] I-know-pres
 'The mother knows the boy arrived'
- (4) *eni-r* [*uz-a* *magalu* *b-ac-ru-li*] *b-iy-xo*.
mother-dat. [boy-erg bread.III.abs. III-eat-pstprt.nmlz] III-know-pres
 'The mother knows that the boy ate the bread'

³ Notations like specifier, complement, among others are used here mostly for convenience. Recent research has challenged their alleged relevance in the present theory and the author follows suit. This paper specifically seeks to show that elements in an agreement relation are 'sisters' at some derivational point, either via Merge or Move. The notations corresponding to these relations (specifier, complement) are hardly of any relevance to the present work. Similarly, since I shed doubt on the very existence of Agree (see Chandra, 2005, in progress), terms like probe and goal are not used in their conventional sense.

⁴ All Tsez examples – unless specially mentioned - are from Polinsky and Potsdam (2001).

Matrix verbs (may) agree with either the subject (3) or the object (4) of their embedded clausal complements. Generally, the embedded verb displays the same (or parasitic) agreement morphology reflected on the matrix predicate.^{5,6} Importantly, the agreeing nominal must always be case-marked absolutive. Agreement with non-absolutive DPs (for instance, the dative nominal in (5)) is unattested in this language:

- (5) *eni-r [uz-a kidbe-r magalu taλ-ru-li] y-iyxo.
mother-dat. [boy-erg. girl.II-dat. bread.abs. give-pstprt-nmlz.] II.know
 ‘The mother knows that the boy gave the girl bread’

LDA is restricted to arguments of clausal complements. Arguments inside adjuncts cannot trigger agreement on matrix predicates, as (6) shows.

- (6) [kid y-ay-zal] enir xabar r/*y—esu-s.
*[girl.II.abs. II.arrive-when] mother-dat news.IV. IV/*II-find-pst.evid*
 ‘When the girl arrived, the mother found out the news’

Tsez LDA is also optional. It may be complemented by clausal agreement, as in (7) with the verb displaying the features of the complement-clause.

- (7) eni-r [uz-a magalu b-ac-ru-li] r-iy-xo.
mother-dat. [boy-erg. bread.III.abs. III-eat-pstprt-nmlz.]-IV IV.know-pres
 ‘The mother knows the boy ate the bread’

Here I must also draw the readers’ attention to the embedded verb, which is overtly marked for (object) agreement despite the absence of LDA. Similar observations hold for (8). Note that this sentence has an overt complementizer, which necessitates clausal agreement.

- (8) eni-r [uz-a magalu b-ac-ru-l] *b/r-iy-xo.
*mother-dat.[boy-erg. bread.III.abs. III-eat-pst.evid-COMP] *III/IV-knows*
 ‘The mother knows the boy ate the bread’

⁵ Agreement morphology is not reflected on certain verbs owing to certain morphophonemic idiosyncrasies of the language.

⁶ Tsez displays obligatory “LDA-like agreement” (Polinsky and Potsdam, 2001) with matrix volitional predicates selecting infinitival complements, constructions we are not concerned with in this paper. However, given that the matrix predicates with infinitival complements are ‘auxiliary-like’ (*be good, be able, want*), one might tentatively extend ‘functional’ restructuring frameworks to these structures (see Cinque, 2001; Wurmbrand, 2001, 2004 for related issues).

LDA is therefore completely ruled out in instances with overt complementizers. In a similar vein, LDA is also impossible with *wh*-phrases – irrespective of their argument or adjunct status (9)-(10).

- (9) *enir* [lu micxir b-ok'ak'-ru-li] r/*b-iyxo.
mother [*who-erg money.III.abs. III.steal-pstprt-nmlz.*] *IV/*III-knows*
 ‘The mother knows who stole the money’
- (10) *enir* [na c'ohor-a micxir b-ok'ak'-ru-li] r/*b-iyxo.
mother [*where thief-erg. money.III. III.steal-pstprt-nmlz*] *IV/*III-knows*
 ‘The mother knows where the thief stole the money’

Non-absolute topics in the embedded clause block LDA as well - the intervening topic could be a fronted adverbial topic (11) or an overtly marked argument topic (12).^{7,8}

- (11) *eni-r* [hul uz-a magalu b-ac-ru-li]
mother-dat. [yesterday boy-erg. bread.III.abs. III-eat-pstprt-nmlz].IV
 r/*b-iy-xo.
*IV/*III-knows pres*
 ‘The mother knows the boy ate bread yesterday’
- (12) *eni-r* [ah-a canaqan-go-gon ziya
mother-dat. [shepherd-erg. hunter-poss.ess-top cow.III.abs.
*bisr-er-xosi-li] r/*b-iy-xo.*
*feed-caus-prtpst-nmlz].IV IV/*III-know-pres*
 ‘The mother knows that the hunter, the shepherd made (him) feed the cow’

The agreement-triggers in LDA constructions are always interpreted as topics. To illustrate with an example, the agreeing nominal ‘the bread’ in (4) - repeated as (13) – must be identified as the topic of the utterance, i.e. an object already referred to in the preceding discourse.⁹

- (13) *eni-r* [uz-a magalu b-ac-ru-li] b-iy-xo.
mother-dat. [boy-erg bread.III.abs. III-eat-pstprt.nmlz] III-know.pres
 ‘The mother knows that the boy ate the bread’

⁷ Non-fronted adjuncts do not block LDA, and neither are they interpreted as topics. As Polinsky and Potsdam (p. 598) note: “...adjuncts become topics by fronting and this fronting is an instance of overt topicalization.”

⁸ Multiple argument topics are allowed in mono-clausal contexts, though the embedded clause scenario remains rather fuzzy in Polinsky and Potsdam’s paper.

⁹ Non-referential NPs (universally quantified NPs and anaphors) cannot be topics, and consequently must not be able to trigger cross-clausal agreement.

Absolute LDA-triggering DPs sometimes bear the (overt) topic marker. In these contexts, the nominal obligatorily triggers LDA. Other agreement possibilities (such as clausal agreement) cannot be entertained here (14).

- (14) enir [uz-a magalu-n/magalu-gon b-ac-ru-li] *r/b-iy-xo.
*mother [boy-erg. bread.III-abs-top III-eat-pstprt-nmzl]. *IV/III-know-pres*
 ‘The mother knows that the bread, the boy ate’

To summarize, Tsez cross-clausal agreement is triggered by absolute DPs embedded in clausal complements. Overt complementizers, adjuncts, wh-phrases and non-absolute topics impede cross-clausal agreement. Finally, LDA-triggering DPs are essentially interpreted as topics.

2 Agree-Based Accounts: A Critique

In this section, we revisit long-distance Agree-based alternatives for Tsez LDA, as proposed by Polinsky and Potsdam (2001) (also see Bhatt, 2005).¹⁰ Polinsky and Potsdam propose (15) as “a useful probe on the syntax of LDA.”

(15) Topic Condition on Long-Distance Agreement

LDA occurs when the referent of the embedded absolute NP is the (primary) topic of the embedded clause.

They claim that the topic interpretation is a reflex of the agreeing nominal’s covert movement to the specifier of an embedded Topic Phrase. (17) represents sentence (16) graphically.

- (16) eni-r [uz-a magalu b-ac-ru-li] b-iy-xo.
mother-dat. [boy-erg bread.III.abs. III-eat-pstprt.nlmz] III-know.pres
 ‘The mother knows that the boy ate the bread’

As illustrated in (17), the agreeing nominal covertly targets the specifier of the TopicP that immediately dominates the lower IP. The matrix *v* thereby (long-distance) Agrees with the embedded nominal placed at the edge of the lower clause. Crucially for Polinsky and Potsdam, the agreeing nominal does not move out of the embedded clause. Secondly, the movement of the agreeing DP to the specifier of embedded TopicP is A-bar movement: the matrix *v* Agrees with a nominal placed at an A-bar position. Topic movement is clause-bound (as it does not cross the lower clause boundary).

¹⁰ For a critique of Bhatt’s account, see Chandra (2006).

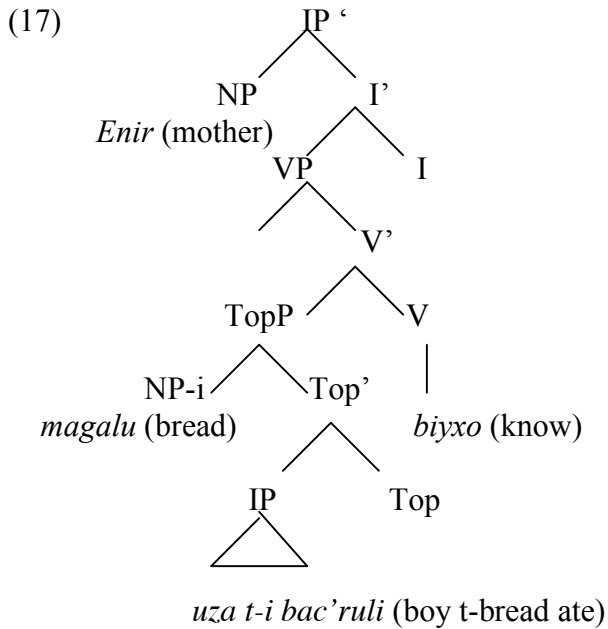

Recall that the agreement triggering nominal is case-marked absolutive. Polinsky and Potsdam opine that “the reason that the trigger must be an absolutive is simply because verbs only show agreement with absolutive arguments.” (p. 286). Since only absolutive case-marked subjects and objects trigger verbal agreement, it follows that only absolutive nominals may trigger cross-clausal agreement. Polinsky and Potsdam then resort to the notion of ‘barriers’ (Chomsky, 1986) to explain the intervention effects caused by overt complementizers, embedded *wh*-phrases and non-absolutive topics. The presence of overt complementizers and *wh*-phrases correlates with the presence of a CP (between matrix *v*P and embedded TopicP) – this blocks government of the specifier of TopicP by matrix *v*. The intervention effects further suggest that either C is a possible governor or that one or more of CP and TopicP is a barrier for head government. On the other hand, fronted adverbial-topics and overtly topic-marked nominals occupy the specifier of TopicP, usurping the landing site for the agreeing nominals. Polinsky and Potsdam acknowledge that their account must rule out the alternative LF representation where the trigger’s (covert) movement precedes the (covert) movement of the non-absolutive topic; i.e the topic must move before the absolutive nominal targets the edge of the phrase.

Let us now move to some immediate problems with the Agree-based account. The first problem is that the ‘rather relaxed’ locality restrictions on agreement relations beget the potentiality of generating some ungrammatical strings. To illustrate with an example:

- (18) *babir [enir [uza magalu bac'ruli] b-iyxosi-li] r/*b-iyxo.*
*father [mother [boy bread-III.abs. ate] III-know-nmlz.] IV/*III.know*
 'The father knows that the mother knows the boy ate bread'

Sentence (18) lacks a CP-complement (note there is no overt complementizer – *yin*). We therefore (incorrectly) predict that the matrix verb must Agree with the argument of the most deeply embedded clause. Consider why. The second highest verb (as in (19)) reflects the phi-features of the object of the lowest clause. With Polinsky and Potsdam, we assume that the object A-bar moves to the specifier of TopicP wherein it enters into Agree with V-2. Note that there are no 'barriers' to bar any possible agreement relations that the nominal may enter into, with any (relevant) higher head (here V-1), contrary to facts.

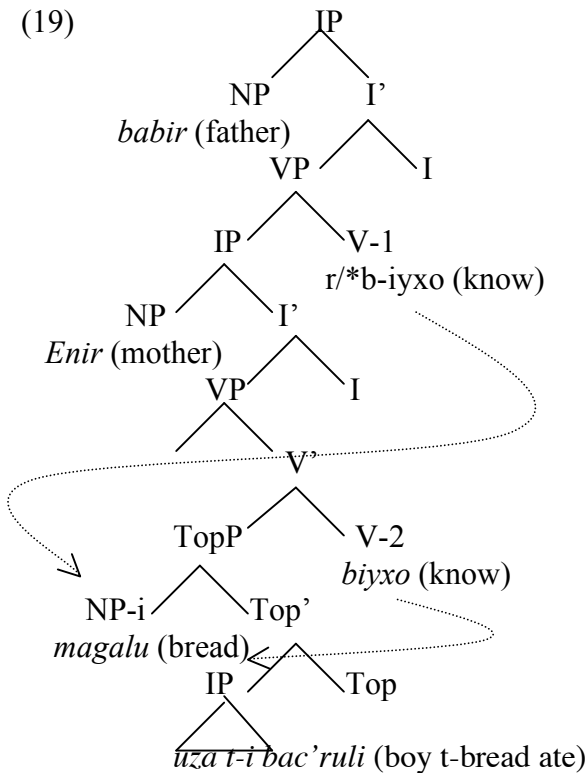

In addition, according to Polinsky and Potsdam's own account, the TopicP cannot be counted as a 'barrier' for the DP positioned in its specifier. It may be argued that the specifier (contra an adjoined position) to TopicP is not in the domain of the higher predicate. This obviously causes a setback to the above criticism, but it likewise poses a serious problem for the Agree based account of Polinsky and Potsdam. If DPs placed at the specifier(s) of Topic heads are inaccessible to

higher heads, cross-clausal agreement cannot be entertained in Tsez at all, as the specifier of TopicP must be rendered inaccessible to even the immediately preceding verbal head. We are then left with a dilemma over whether to maintain the Agree based account for LDA and lose the explanation for lack of successive-cyclic agreement or to keep the explanation for the latter constant and compromise on the arguments for Tsez LDA. Either way, Agree makes incorrect predictions for LDA.¹¹

The other unresolved issue concerns the distribution of Topic heads in the structure. Polinsky and Potsdam’s account provides no justification for why the TopicP is restricted to the most deeply embedded clause. There is by far no known general restriction on long-distance topic movement in other languages (take the Hindi-Urdu example in (20), for instance), so the lack of a topic phrase in the second embedded clause remains unmotivated.

- (20) johnkoto, mary hamesha jaantii thii miraa pyaar kartii he.
John-top Mary always know be-past Mira love do be-prst
 ‘Mary always knew that Mira loved John’

The problem is obviously more general than just the ban on embedded triggers moving to the specifier of a higher TopicP. Tsez disallows all types of long distance A-bar movement. See (21), an unacceptable form with long-distance wh-movement.

- (21) *sebi enir riyxo [c’ohora rok’ak-ru-li]
what.abs. mother knows [thief-erg. steal.pstprt.nmlz]
 ‘What does the mother know that the thief stole?’

At a more superficial level, the ban on moving the agreement trigger to a higher TopicP can be traced to the overall prohibition on long distance A-bar dependencies in Tsez grammar. Unfortunately, this displaces the problem more than solving it. It is necessary that we resolve the matter by providing an

¹¹ An anonymous reviewer suggests that Polinsky and Potsdam could appeal to ‘Relativized Minimality’ effects: the A’-agreement established by the verb of the intermediate clause blocks A’-agreement with the more remote matrix verb. I tend to disagree with this possible solution since (i) it is unmotivated and unattested elsewhere (consider the A’-agreement on intermediate C’s in languages like Irish where A’-agreement does not block further A’-agreement, see McCloskey, 2000) and (ii) it assumes that heads can be (defective) interveners (à la Bhatt, 2005); this does not fit into the original conception of the notion (see Chomsky, 2000), (iii) ‘defective intervention’ is itself a problematic notion enforced into Match and Agree, themselves dependent on a primitive, representational notion of c-command (see Chandra, forthcoming, in progress for elaborate discussion).

explanation for this characteristic before considering it as the basis for explaining other properties of the language.

Polinsky and Potsdam make a second controversial claim by suggesting that Tsez LDA is triggered by nominals placed at A-bar positions (specifier of TopicP). This (falsely) opens the possibility of other A-bar elements like wh-phrases and focused nominals triggering cross-clausal agreement. However, this claim is not substantiated: focused elements cannot trigger cross-clausal agreement (22). In instances where the absolutive nominal bears a focus marker, clausal agreement becomes obligatory. The focused nominal is shown in small caps below.

- (22) eni-r [t'ek-kin y-igu yal-ru-li] r-iy-xo *y/r--iy-xo.
*mother-dat. [book.II.abs-foc. II-good be-pstprt-nmlx]. *II/IV.know.pres*
 'The mother knows that the BOOK is good'

The problem becomes more puzzling once we start considering cross-clausal agreement with focused elements in other languages such as Innu-aimûn (Branigan and MacKenzie, 2002; Ritter and Rosen, 2005). Innu-aimûn, an Algonquian language also displays cross-clausal agreement between matrix predicates and arguments of their 'finite' clausal complements. The agreement triggers are generally associated with a topic interpretation.¹²

- (23) Ni-tshissenitamun-anan mupishtuat Shushépa Tshan mak Mani.
1pl-know-TI-1pl. visit Joseph John and Marie
 'We know that John and Marie visited Joseph'
- (24) Ni-tshissenim-anan-at mupishtuat Shushépa Tshan mak Mani.
1pl-know-1pl-3pl. visit Joseph John and Marie
 'We know that John and Marie visited Joseph'

The matrix verb in (23) bears TI (transitive-inanimate) agreement, corresponding with either the clausal complement or reflecting default agreement triggered by the lack of [+/- animate] features on the complement. (24), on the other hand, is a case of cross-clausal agreement with the matrix verb agreeing with the embedded subject.

Central to our discussion here is the fact that Innu-aimûn focused elements and wh-phrases are eligible candidates for triggering cross-clausal agreement.

¹² The Innu-aimûn examples are from Branigan and Mackenzie (2000, 2002).

- (25) Ni-tshissitu-au Mani muk^u uitshiepan Aniu.
1-remember-1/3 marie only helped Annie
 ‘I remember that only MARIE helped Annie’
- (26) Tshi-tshissenim-aut-a tan tat innut tshe-takushinit?
2-know-3pl-Q how many people fut-arrive
 ‘Do you know who is laughing?’

The acceptability of instances like (25)-(26) has led some researchers to suggest that Innu-aimûn allows agreement from A-bar positions. The same observation cannot be made for Tsez focused and wh-phrases, though.¹³ Moreover, there are at least two other differences between Innu-aimûn and Tsez that are noteworthy here. First, Innu-aimûn – unlike Tsez – optionally allows the LDA triggering nominal to raise to the matrix clause. Branigan and MacKenzie provide the following intra-language contrast:

- (27) Ma tsh—tshissenim-au [CP tan ishpush Pun utshimama aimiepan Maniua]?
Q 2-know-3sg. [when Paul boss called Marie]
 ‘Do you know when Paul’s boss called Marie?’
- (28) Ma tshi-tshissenim-au Pun utshimama [CP tan ishpush aimiepan Maniua]?
Q 2-know-3sg. Paul boss [when called Marie]
 ‘Do you know when Paul’s boss called Marie?’

This option – of overtly displacing the agreement triggering nominal (28) – is available only to Innu-aimûn. I take this to suggest that clausal complements in this language do not bar embedded elements from targeting higher positions in the tree. A second and related difference worth highlighting here is that Innu-aimûn – unlike Tsez – also allows long distance wh-movement.^{14, 15}

Both these properties specific to Tsez – the lack of long distance A-bar dependencies and the lack of cross-clausal movement of the agreement trigger in LDA constructions – substantially feed the alternative that we suggest in the following sections.

¹³ Ritter and Rosen (2005) present evidence suggesting that Innu-aimûn lacks A-movement altogether. If they are right, then phi-feature agreement in this language is confined to A-bar positions in general.

¹⁴ Branigan and MacKenzie (2002) explicitly mention this specific property of Innu-aimûn (p.387), but do not provide an example.

¹⁵ Undeniably, it is not so obvious that two languages must behave similarly with regard to agreement with all A-bar elements. However it still begs the question as to why a focused or a wh-phrase placed at the specifier of a CP (taken either as a barrier or a phase) should be inaccessible to the higher verbal head for Agree or Move in Tsez, but not in languages like Innu-aimûn.

3 Proposing a More Local Alternative

I propose that LDA structures like (29) have the underlying representation as in (30).

- (29) *eni-r [uz-a magalu b-ac-ru-li] b-iy-xo.*
mother-dat. [boy-erg bread.III.abs. III-eat-pstprt.nmlz] III-know.pres
 ‘The mother knows that the boy ate the bread’

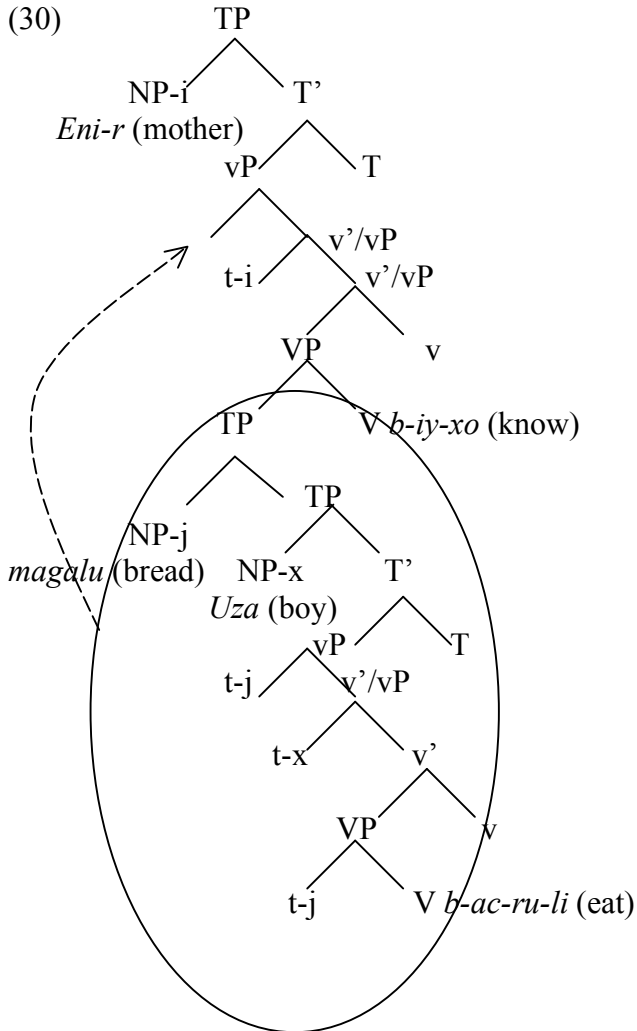

In (30), the embedded object first moves to the specifier of the lower (defective)¹⁶ vP, where it checks the phi-features on v. This movement places it in the same minimal domain as the lower subject, making them equidistant from a further

¹⁶ See section 3.2 for arguments justifying this claim.

goal. The subject then moves to the specifier of TP while the object overtly adjoins to TP (akin to embedded topics). I then assume that the TP-complement (overtly) moves to the specifier of matrix vP (also see Koopman, 2003; Frank, 2005).¹⁷ At this derivational point, the raised structure undergoes reprojection: the absolutive topic ‘projects’, replacing the existing TP-label (see 31). Consequently, the specifier of vP is occupied by a DP, whose D head – the absolutive topic – agrees with the phi-set of the matrix v. LDA is thereby accomplished in a ‘local’ relation.

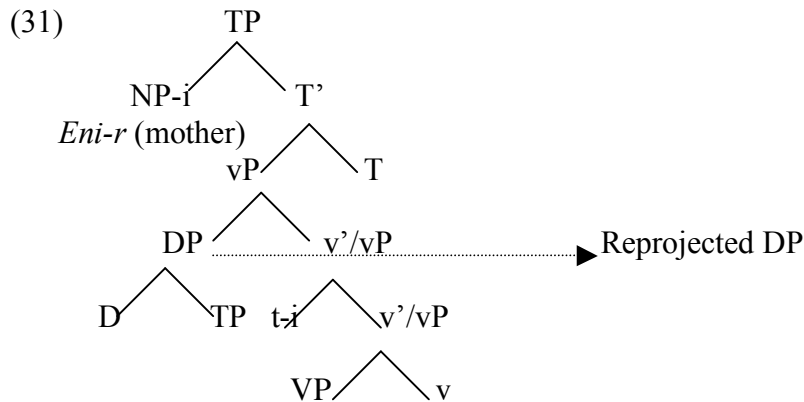

3.1 Necessary Details In this section, I elaborate on three points central to the alternative analysis proposed here: (i) adjunction of the absolutive-topic to embedded TP, (ii) obligatory clausal complement raising to the specifier of matrix vP, (iii) agreement between v and the reprojected DP. Let us consider each of these issues one by one now.

3.1.1 Embedded Topics I follow Boskovic (1997) and Pesetsky (1989) in claiming that embedded topics target adjoined positions. The English sentence in (32) illustrates this point¹⁸:

(32) Peter does not believe that [IP Mary [IP John likes]].

In (32), the topic is placed to the right of the complementizer ‘that’, suggesting that the topic targets a position lower than CP, presumably a TP-adjoined

¹⁷ Thanks to Cedric Boeckx for drawing my attention to these studies. See Chandra (2006) for a critical discussion.

¹⁸ The English examples with topicalization are taken from Boskovic (1997).

position. That the topic cannot target a CP is evident from the contrast between the two sentences in (33)-(34).¹⁹

(33) * I wonder [CP to John [CP which book Peter should give]].

(34) ?? I wonder [CP to whom [IP this book [IP Peter should give]]].

Going back to LDA sentences like (29), I claim the object raises and adjoins to embedded TP. There are two options to consider here. First, say there is a topic feature to be checked on T. The nominal satisfies this requirement from a TP-adjoined position:

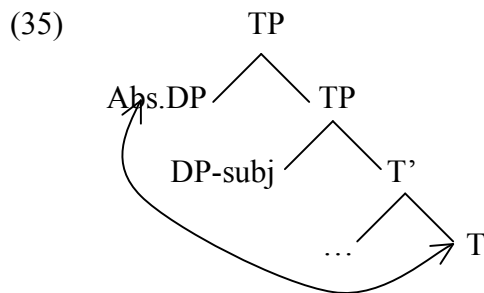

This checking configuration is in line with Chomsky's (1993) formulation of 'checking domain': the minimal or the smallest subset of the set of nodes – such that every element in the set is reflexively dominated by some element in the subset - *contained*²⁰ in Max X excluding the head and its complement. The 'checking domain' of T in (35) is a heterogeneous set including as its members, the specifier and all adjoined elements, namely {Abs.DP, DP-subj}. Therefore the topic feature on T is checked by an element (Abs. DP) enclosed within its minimal checking domain. Though this suffices for drawing a non-Agree based, 'local', sisterhood relation between the participating elements, I would like to propose a different alternative here (see Chandra 2006 for possible loopholes).

We assume with Franks and Lavine (2006) and Boskovic (2002) that elements – in their pursuit for eligible functional heads/checkers – may target intermediate positions without any immediate feature-checking motivation. As for instance, a DP seeking a head to value its uninterpretable case feature may target an intermediate node without necessarily triggering agreement with it. We can suggest something similar for Tsez LDA constructions. DP moves agnostically to

¹⁹ I am assuming the minimal functional structure (CP-TP-vP) here. Alternatives may be sought within Cinque-style cartographic approaches.

²⁰ X *contains* Y iff some segment of X dominates Y, whereas X *includes* Y iff every segment of X dominates Y. The category-segment distinction (Chomsky, 1986; May, 1985) isolates adjoined positions from specifier positions, since only the latter are *included* by the respective head.

TP. They do not enter into any feature checking relation.²¹ The sole motivation of the movement is to place the absolutive as close as possible to the higher target. I stick to this alternative for the rest of the paper.

If this analysis holds, it raises the following questions. First, why can't the DP itself move out of the TP to the specifier of matrix v? Second, how does the DP – adjoined to TP – enter into a sisterhood relation with v without directly merging with it? The following sub-sections attempt to answer these questions.²²

3.1.2 Clausal Pied-piping Recall that I claimed obligatory, overt clausal pied-piping to the specifier of matrix vP in Tsez LDA constructions. This claim is partly motivated by the fact that Tsez allows (optional) clausal agreement:

(36) eni-r [uz-a magalu b-ac-ru-li] r-iy-xo.
Mother-dat. [boy-erg. bread.III.abs. III-eat-pstprt-nmlz.]-IV IV.know-pres
 'The mother knows the boy ate the bread'

I assume that the embedded clause in (36) is a CP; C has a set of interpretable phi-features that it checks against the higher verbal head. On the other hand, such a clear case cannot be made for the presence of phi-features on T heads, since clausal agreement can be easily substituted by LDA in the absence of overt complementizers. I assume that in the absence of C, the phi-set on T is incomplete. This tallies well with Chomsky's (2000, 2001a, b) observations on the interactions between different functional heads: if selected by C, T is phi-complete; in all other cases, T is phi-incomplete. Tsez T is similarly phi-incomplete when not selected by a C (which may or may not manifest overtly). LDA is restricted to such instances.

Reverting our attention to clausal complements with full phi-feature specification (or in other words CPs), I claim that these move to the specifier of the matrix v, triggering agreement on it. There is one immediate advantage to this claim. It helps us motivate an important generalization in Tsez grammar, namely the inability of generating long distance A-bar dependencies (37).

(37) *sebi enir riyxo [c'ohora rok'ak-ru-li]
what.abs. mother knows [thief-erg. steal.pstprt.nmlz]
 'What does the mother know that the thief stole?'

²¹ A more important point to note here is that it renders the TP-adjoined position useless at LF, as it bears no interpretative significance.

²² I remain agnostic over whether the DP adjoins to TP or simply moves to a second specifier of TP. Either way, in cases of reprojection, the DP becomes a sister to TP whereas initially it is sister to TP or T'.

The core idea - along the lines suggested in Uriagereka (1999) – is that once the entire CP pied-pipes to the specifier of matrix v – detaching itself from the main structural skeleton- its internal structure freezes on being targeted by the Spell-out operation. This turns the CP into an island whose terms can no longer target positions outside CP for movement. Non-absolute topics, focused elements and *wh*-phrases that move to the edge of the pied-piped clause are therefore rendered inactive for movement out of the embedded clause.

Likewise, TP’s phi-set makes it an eligible goal for any higher functional head. So with the DP also hosting a set of interpretable phi-features, we have a structure like the following:

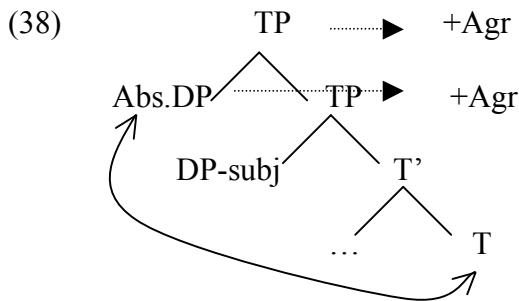

As in (38), TP bears the same set of features as the absolutive DP. Matrix v requires an appropriate goal. Both TP and DP are eligible candidates. However, the former’s closeness to v (than DP’s) makes it the more eligible candidate for movement. Contemplate on what happens if the absolutive DP instead moves in (38). If we overlook the category distinctions and consider just feature-identity, choosing DP over TP is a violation of the A-over-A principle (itself derived from Minimality effects, see Hornstein, 2005). TP movement over DP in Tsez LDA constructions is therefore aptly justified. Crucially, clausal pied-piping must be overt in Tsez; otherwise we lose an explanation for why this language lacks long-distance A-bar dependencies. A second important point to consider is the timing of the absolutive DP-reprojection (see below) vis-à-vis TP pied-piping in LDA instances. Allowing DP-reprojection to precede clausal pied-piping would raise some selectional problems: if DP reprojects immediately after its adjunction to TP, TP’s selection by matrix v remains a mystery. The matrix verb in LDA constructions selects a clausal complement, not a DP. Therefore it must be that reprojection follows clausal pied-piping.²³

²³ Later on, I argue that DP-movement and subsequent reprojection seems possibly driven for case/phi-feature checking. The raised nominal is interpreted as a topic or definite by virtue of holding the left edge of the embedded clause. I remain agnostic on whether DP bears an actual topic feature.

3.1.3 DP Reprojection & Local Agreement Clausal pied-piping generates the following representation:

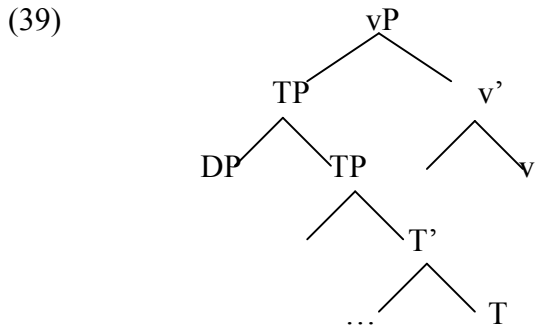

At this derivational instant, the absolutive projects itself and substitutes the erstwhile TP. This phenomenon is called ‘reprojection’ (Hornstein and Uriagereka, 2002). Below I expound on the concept a little more.

Hornstein and Uriagereka maneuver a standard assumption in the minimalist literature: merge takes two elements X and Y, and generates a complex structure {L, {X, Y}}, where the label L is identical to either X or Y (40)-(41).

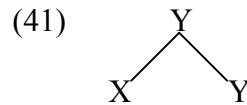
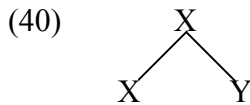

Reprojection emerges naturally in a (at least, partially) derivational system with ‘merge’ as its basic operation: it permits a single geometrical object to be accessed from two different vantage points, as schematized below: the XP-specifier of (42) may reproject, forcing its Y’ sister to be interpreted as a maximal projection YP (43).

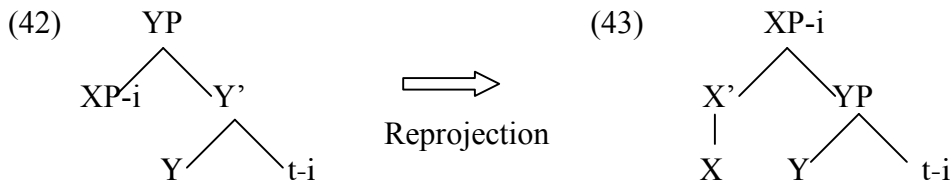

I extend this basic mechanism to Tsez LDA constructions and propose that absolutive topics reproject after clausal pied-piping to the specifier of matrix v.

The absolutive DP – adjoined to TP in (44) – projects itself in (45), while the rest of lower TP remains the same.

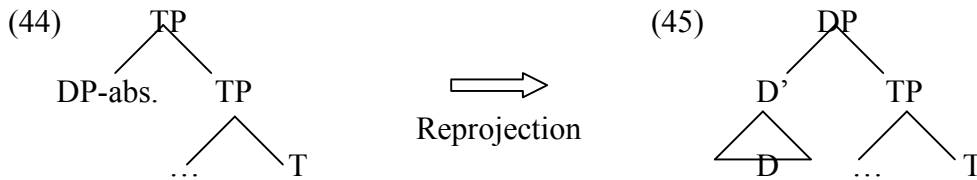

Let us next reflect on the exact timing of reprojection. Hornstein and Uriagereka consider reprojection as an LF phenomenon. This assumption is essential in order to avoid linearization problems: reprojection alters existing c-command relations. In (42), the XP-specifier precedes Y', whereas the opposite holds true for (43), where YP (the erstwhile Y') now precedes X'. A similar situation obtains in the adjustment from (44)-(45): what was initially the adjoined DP now becomes the head (D) following TP. One option is to therefore assume that reprojection is a LF phenomenon. We then derive the OSV word order (in the embedded clause), with the DP-adjoined to TP – asymmetrically c-commanding TP (44). The SOV order can be derived via overt PF scrambling of the subject.

A second option is to allow overt reprojection. We then assume that TP is accessed by PF before it moves to the specifier of matrix v. In this way, we derive the OSV order with (44). Subject scrambling at PF gives us the alternate structure.

Let us now return to the structure after DP-reprojection (46), wherein the reprojected DP enters into phi-agreement with matrix v in a local, sisterhood relation.

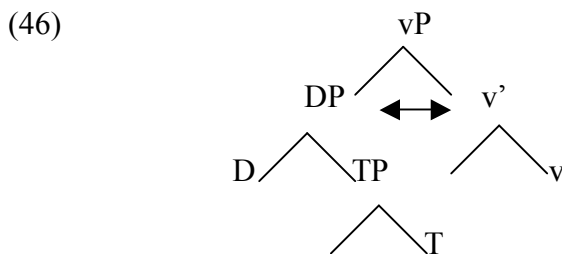

There is one remaining question: why should the DP be chosen for agreement over the TP? Since TP has the relevant features, it is seemingly an equally appropriate candidate for checking v's features. As an answer, I highlight the incompleteness of T's phi-set. It is standardly assumed that the phi-set of a 'goal' must be complete in order to accomplish agreement. Keeping this reasoning in

mind, incomplete T cannot check the feature-set of *v*. In the absence of an appropriate goal, the phi-features on *v* would remain unchecked leading ultimately to a derivational crash. A similar reckoning can be made from the perspective of the absolutive DP (see section 3.2).

To summarize, we have argued that the embedded nominal that triggers agreement on the matrix verb patterns like embedded topics and targets an embedded TP adjoined position. This movement is agnostic and has no feature checking motivation. The nominal checks the phi-set on matrix *v* after clausal pied-piping and DP-reprojection. Matrix *v* enters into a ‘local’ relation with DP, and consequently displays the former’s phi-feature value. The term ‘local’ relations are used to encompass all structural configurations generated by the structure-building operation Merge, specifically specifier-head and head-complement. However note that the absolutive trigger is ‘initially’ not in a sisterhood relation with *v* (i.e. it does not (directly) merge with *v*). Reprojection’s relevance comes in here: reprojecting DP engenders a sisterhood relation between *v* and the absolutive which cannot move out of the TP containing it. Reprojection therefore creates the appropriate structural configuration for agreement.

We now address another pressing issue: case-assignment and its relation to the mechanism of cross-clausal phi-feature checking.

3.2 Case Matters As already noted, agreement-triggering nominals are obligatorily marked for absolutive Case. We need an account for where this case is assigned. In Agree-based accounts, absolutive case is (presumably) checked in the lower clause (see Bhatt, 2005 for a clearer statement). This suggestion concurs with the observation that the lower TP - by virtue of being a finite clause – satisfies all the case requirements on the embedded nominals. Additionally, it is stipulated that nominals that are case-marked at a prior point in the derivation are still active to the computational system. We now provide some arguments contradicting such claims. Take the following illustration:

- (47) *eni-r* [*uzi* *φ-ay-ru-li*] *φ-iy-xo*.
Mother-dat. [boy.I.abs. I-arrive-pstprt.nmlz] I-know-pres
‘The mother knows the boy arrived’

The lower verb in (47) is an unaccusative. That leaves us with two potential absolutive Case-checkers in the structure: (i) (embedded) T or (ii) matrix *v*. There is at least one (though somewhat indirect) argument against considering T as the absolutive Case-checker in Tsez. The evidence comes from ambiguous scopal patterns in the language. As observed by Polinsky and Potsdam, clause-mate

ergative subjects and objects may scope over each other (48). I take this to imply that the ergative subjects reconstruct (to the specifier of vP) in this language.²⁴

- (48) sibaw ay-a sis k'et'u han-si.
Every dog-erg. one cat-abs. bit-pstprt
'Every dog chased a cat'
Every dog > a cat
A cat > every dog

Nevins and Anand (2003) provide evidence from languages from Hindi-Urdu, English and Russian suggesting that movement to TP, driven solely for the EPP generates scope rigidity, i.e. subject reconstruction below a clause-mate object is impossible when its movement to TP is not for case and agreement. Constructions that typically reflect scope rigidity (in Hindi-Urdu, for example) involve ergative subjects. Hence they claim that ergative Case in these languages is lexical and that ergative subjects move to TP for pure EPP reasons. In a nutshell, T cannot value structural Case. The following example from Hindi-Urdu emphasizes this point:

- (49) kisi shaayarne har ghazal paRhii.
Some poet-erg every song-acc.sg.fem. read.sg.fem.perf
'Some poet recited every song'
Some poet > every song
*every song > some poet

Unlike Hindi-Urdu ergative subjects, ergative subjects in Tsez may reconstruct and take narrow scope vis-à-vis absolutive objects. By parity of reasoning, DP-movement to the specifier of TP must be driven for reasons other than just the EPP: presumably structural (ergative) case and phi-feature agreement checking (also see Polinsky and Potsdam, 2001 for arguments that the ergative subject is structurally higher than the absolutive object in simple matrix clauses). If we adopt this line of reasoning, it must be v that assigns absolutive Case in Tsez. For LDA structures with embedded, unaccusative predicates like (47) then, the agreement triggering nominals are valued absolutive by the matrix verb.^{25,26}

²⁴ As Norbert Hornstein (pc) and an anonymous reviewer point out, (48) is not the most suitable example to show scope ambiguity in the language. However, Maria Polinsky (pc) informs me that scope ambiguity holds in constructions with different quantifiers too.

²⁵ Long passives are good diagnostics for testing if the higher verb is a case-checker. For lack of more data, I restrict myself to these preliminary observations.

²⁶ For object-triggered LDA constructions, I will assume that the lower v is defective, hence unable to check structural case on the object. On the other hand, if we were to assume that lower v checks the absolutive case-feature, the nominal may bear another 'feature' (possibly another

The benefit of conjecturing a strong case-agreement tie-up is that we no longer require stipulating that nominals remain active for computational operations after they have been case-checked. Second, it allows us to analyze LDA on par with Tsez mono-clausal agreement. For sentences like (50)-(51), we assume – as we do with bi-clausal LDA structures – that the ‘absolutive’ DP receives an absolutive value for its structural Case feature as a reflex of phi-feature checking with *v*. The alternative analysis advocates a ‘continuity’ that is absent in studies that treat mono-clausal and bi-clausal agreement differently.

- (50) *ziya b-ik'i-s.*
cow.III.abs. III-go-pst.evid
 ‘The cow left’
- (51) *eniy-a ziya b-iser-si.*
Mother-erg. cow.III.abs. III-feed-pst.evid
 ‘Mother fed the cow’

4 Revisiting Intervention Effects

With these assumptions in the background, let us now proceed to the intervention effects observed in LDA constructions. Recall first, that LDA is impossible in the presence of overt complementizers.

- (52) *eni-r [uz-a magalu b-ac-ru-□] *b/r-iy-xo.*
*Mother-dat. [boy-erg. bread.III.abs. III-eat-pst.evid-COMP] *III/IV-knows*
 ‘The mother knows the boy ate the bread’

A complementizer in (52) implies the presence of an embedded CP. As in (53), the embedded C bears agreement features. It agrees with matrix *v* by moving to the probe’s checking domain. The ‘reprojected’ DP is not in a close sisterhood relation with *v*. Consequently it fails to trigger verbal agreement. This explains why LDA and overt complementizers do not co-exist.

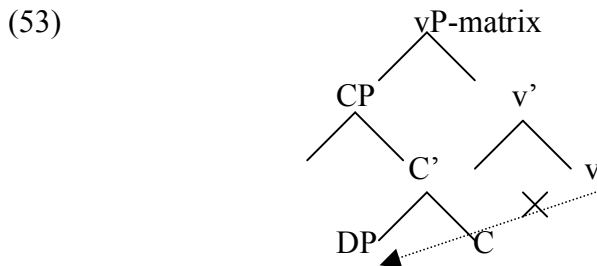

unvalued structural case) that enables it to trigger verbal agreement in the matrix clause. Needless to mention, these issues will be settled on more thorough investigation of case matters in Tsez.

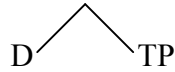

It is worth pondering on another important issue at this point: the absence of topic interpretation with absolutive DPs not triggering LDA (as in (52)). We noted above that topic interpretation strictly correlates with cross-clausal agreement. In our system, that would mean that absolutive nominals that do not trigger agreement on the matrix verb do not raise and adjoin to TP. Rather, they raise as far as the specifier of lower *v* (non-defective, in this case), against which they value their structural Case feature. This in turn provides some more insight into the case-agreement correlation in LDA constructions. Let me elaborate on this matter here. Consider a derivation where the (absolutive) nominal checks its Case against the lower verb and then checks a topic feature on embedded T. In the presence of C, it fails to trigger agreement on the higher verb, as the former is a closer goal to *v* than DP. The final output is a non-LDA construction. Note, there is nothing that should rule out this derivation, as all uninterpretable features that could plausibly lead to a crash at the interfaces have already been disposed – the structural Case on the embedded topic and the phi-set on matrix *v* (checked by C). What then disallows the appearance of absolutive *topics* in non-LDA structures? This issue is completely overlooked in previous accounts of LDA, which establish topics as agreement triggers – with no special emphasis paid to the role of case-assignment in the entire process. We now provide an answer for this puzzle and conjecture that absolutive DP-movement to embedded TP is itself greedy, as the nominal must check off its own uninterpretable case-feature. If it is unable to do so (as with the presence of CP), the derivation will ultimately crash. On the other hand, in contrast to LDA structures where absolutive topics move to TP for case reasons, nominals in non-LDA constructions check their case against lower (non-defective) *v*. They are therefore invariably branded as non-topics.

Next, LDA is also impossible with embedded non-absolutive *wh*-phrases. The presence of a *wh*-phrase likewise coincides with the presence of an intermediate CP. The TP-adjoined/reprojected, absolutive nominal cannot establish a close relation with *v*. Hence a non-LDA output like (54):

- (54) enir [lu micxir b-ok'ak'-ru-li] r/*b-iyxo.
*Mother [who-erg money.III.abs. III.steal-pstprt-nmlz.] IV/*III-knows*
 'The mother knows who stole the money'

Our analysis however predicts that non-absolutive topics – which do not trigger agreement on the higher verb – may adjoin to TP in the presence of CP. Such a combination is permitted since non-absolutive DPs do not have an uninterpretable

case feature to check against the higher verb. The sentence in (55) – with a wh-phrase and a topic – confirms our predictions.

- (55) nar elude-r(-no) za nex-xo.
Where we-dat-(top) he.abs. approach-pres
 ‘Where will he approach us?’

Further, non-absolutive topics also bar cross-clausal agreement. Consider (56).

- (56) eni-r [ah-a canaqan-go-gon ziya
Mother-dat. [shepherd-erg. hunter-poss.ess-top cow.III.abs.
 bisr-er-xosi-li] r/*b-iy-xo
*feed-caus-prtpst-nmlz].IV IV/*III- know-pres*
 ‘The mother knows that the hunter, the shepherd made (him) feed the cow’

Within our system, the non-absolutive DP usurps the position of the absolutive topic. Consequently the latter fails to reproject and trigger verbal agreement from its ‘low’ position in the structure. On the other hand, if the DP-absolutive were to target the TP-adjoined position before the non-absolutive DP, an uninterpretable topic feature would be left unchecked (assuming that topic feature of the non-absolutive DP must be checked by its obligatory movement to the domain of TP, either overtly or covertly).

How accurate this analysis is, crucially depends on whether Tsez allows multiple topics. For if multiple topics are allowed, there is nothing that should bar multiple TP-adjunction: the non-absolutive DP adjoins to TP, followed by TP-adjunction of the absolutive DP. At least apparently, the data seems to suggest that multiple topics are allowed in Tsez. Examine the following sentences, taken from Polinsky (2000) with adverbial and argument topics co-existing in the same structure.

- (57) hul-no uz-a-gon magalu b-ac’-no.
yesterday-top. boy-erg-top. bread.III.abs. III.eat-pst.non.evid
 ‘Yesterday, as for the boy, he ate the bread’

- (58) hul-no uz-a magalu-n b-ac’-no.
yesterday-top. boy-erg-top. bread.III.abs-top. III.eat-pst.non.evid
 ‘Yesterday, as for the bread, the boy ate it’

These structures seem to suggest that multiple topics are allowed, and hence multiple TP-adjunction must be allowed in Tsez. On closer inspection however, the presence of multiple TP-adjunction is not so obvious. The first thing to note

about (57)-(58) is that they involve adverbial-argument topic combinations and not argument-argument topic pairs, as those we are mainly concerned with here. Second, in order to rule out our proposal, one must find evidence suggesting that multiple topics strictly correspond to multiple TP-adjunction. For instance, one piece of evidence for multiple TP-adjunction would be the absence of any precedence relations between the two topics. As both XPs adjoin to the same head, linear order between them must be irrelevant. We test our hypothesis against the data at hand – the adverbial-argument topic combinations – and evidently this is not the case. Given a pair of topics in a structure, adverbial topics must precede argument topics.

- (59) *uz-a-gon hul-no magalu b-ac'-no.
boy-erg-top.yesterday-top. bread.III.abs. III.eat-pst.non.evid
 'As for the boy, yesterday, he ate the bread'
- (60) *magalu-n hul-no uz-a b-ac'-no.
bread.III.abs-top. yesterday-top. boy-erg-top. III.eat-pst.non.evid
 'As for the bread, yesterday, the boy ate it'

I infer from the contrast between (57)-(58) and (59)-(60) that adverbial topics move to CP-specifiers and necessarily precede argument topics that are adjoined to TPs. If true, then the multiple topic constructions cited here have nothing substantial to say for or against our claim that argument topics compete for the same TP-adjoined position.^{27,28}

Moreover, if adverbial topics target CP-specifiers, the unacceptability of structures like (61) - with embedded adverbial topics and agreement triggering absolutive DPs - is easily explained. The presence of CP prevents the absolutive DP from positioning itself in the domain of the matrix verb.

- (61) eni-r [hul uz-a magalu b-ac-ru-li]
mother-dat. [yesterday boy-erg. bread.III.abs. III-eat-pstprt-nmlz].IV
 r/*b-iy-xo.
*IV/*III- knowspres.*
 'The mother knows the boy ate bread yesterday'

²⁷ The most relevant structures for us are those that involve co-occurring embedded, non-absolutive topics (eg. an ergative subject and a dative indirect object). However even for these constructions – if they do exist - we could assume that the ergative subject-topic is at the specifier of TP, while the non-absolutive topic targets the sole TP-adjoined position.

²⁸ English embedded adverbial-argument topic-pairs display a similar behavior. I take the following examples from Culicover (1996).

- (i) They insisted that on Sundays, the promises you made you always have to keep.
 (ii) ??They insisted that the promises you made, on Sundays, you always have to keep.

Finally, we need an account for why absolutive nominals inside adjunct clauses fail to trigger clause-clausal agreement:

- (62) [kid y-ay-zal] enir xabar r/*y—esu-s.
*[girl.II.abs. II.arrive-when] mother-dat news.IV. IV/*II-find-pst.evid*
 ‘When the girl arrived, the mother found out the news’

For structures like (62), the absence of LDA is not surprising. The nominal embedded inside the CP-adjunct is not within the domain of the probe (matrix *v*). This obliterates any possibility of establishing an agreement relationship between them

To review the main points raised in this section, we have demonstrated that absolutive DPs fail to trigger verbal agreement on the matrix verb in instances where either the left edge has an extra functional layer (over and above the TP to which the nominal adjoins) or when the left-most edge itself is occupied by another nominal. In both cases, the absolutive fails to reproject and agree with the matrix verb.²⁹

5 Conclusion

To conclude, on closer scrutiny, we observed that Agree-based accounts of Tsez LDA not only fail to adequately capture all its associated characteristics but also end up making some incorrect predictions about it. As an alternative, we proposed that the absolutive trigger targets an embedded TP-adjoined position. Next comes TP pied-piping to the specifier of the higher *v*P, after which the absolutive DP reprojects and agrees with the matrix verb.

In addition, we provided evidence suggesting that unlike previous accounts – that assume that the absolutive DP triggers verbal agreement from an A-bar position, LDA involves case-checking on the absolutive trigger by *v*. This confirms that nominals can enter into phi-feature checking as long as they have an unchecked structural Case feature that keeps them visible to the computational system. Once’s a DP’s case feature is checked, it becomes inactive for all phi-feature related computations.

Acknowledgments

I must extend my gratitude to the following people: for written comments on earlier drafts of the paper, Cedric Boeckx and Norbert Hornstein; for helpful discussion and immeasurable help with the data, Maria Polinsky; for useful comments on ‘reprojection’ and related issues, Jairo Nunes and Juan Uriagereka;

²⁹ Polinsky and Potsdam raise some further issues, with ‘local’ (specifier-head) accounts. The main problems revolve around scope, constituency tests etcetera. I provide a detailed discussion of how these criticisms do not hold for the alternative account proposed here in Chandra (2006).

and for frequent and enjoyable sessions on agreement and more, Youngmi Jeong. Thanks also go to two anonymous reviewers for thorough investigations of the paper. Unfortunately, I was unable to incorporate all the suggestions here because of space and time constraints. Finally, I must acknowledge the efforts of the editors, specifically in improving the readability of my paper.

References

- Bhatt, R. 2005. Long Distance Agreement in Hindi-Urdu. *Natural Language & Linguistic Theory* 23, pp.757-807.
- Branigan, P. and MacKenzie, M. 2000. How much syntax can you fit into a word? Late Insertion and verbal agreement in Innu-aimûn. *Workshop on Structure and Constituency in Languages of the Americas* 5. University of Toronto.
- Branigan, P. and MacKenzie, M. 2002. Altruism, A-bar movement and object agreement in Innu-aimûn. *Linguistic Inquiry* 33, pp.385-407.
- Boskovic, Z. 1997. *The syntax of nonfinite complementation: An economy approach*. Cambridge, MA: MIT Press.
- Boskovic, Z. 2002. A-movement and the EPP, *Syntax*. 5, pp.167-218.
- Cagri, I. 2004. The EPP of T in Turkish. In P. Chandra, T. Fujii, U. Soltan, M. Yoshida, (eds.) *University of Maryland Working Papers in Linguistics* 13, pp.37-52.
- Chandra, P. 2005. Hindi-Urdu Long-Distance Agreement: Agree, AGREE or Spec-Head? Unpublished Manuscript, University of Maryland, College Park.
- Chandra, P. 2006. Agreement via Reprojection. Unpublished Manuscript, University of Maryland, College Park.
- Chandra, P. forthcoming. Intervention Effects in Agreement: Comparing Hindi-Urdu and Tsez. In the *Proceedings of the 42nd Annual Meeting of the Chicago Linguistic Society*, Chicago.
- Chandra, P. in progress. Reanalyzing Defective Intervention. Unpublished Manuscript, University of Maryland, College Park.
- Chomsky, N. 1986. *Barriers*. Cambridge, MA: MIT Press.
- Chomsky, N. 1993. A minimalist program for linguistic theory. In K. Hale and S. Keyser, (eds.) *The View from Building 20: Essays in linguistics in honor of Sylvain Bromberger*. Cambridge, MA: MIT Press.
- Chomsky, N. 2000. Minimalist Inquiries: The Framework. In R. Martin, D. Michaels and J. Uriagereka, (eds.) *Step by Step*. Cambridge, MA: MIT Press, pp.89-155.
- Chomsky, N. 2001a. Derivation by Phase. In M. Kenstowicz, (ed.) *Ken Hale: A Life in Language*. Cambridge, MA: MIT Press, pp.1-52.

- Chomsky, N. 2001b. Beyond Explanatory Adequacy. A. Belletti, (ed.) *Structure and Beyond*. Oxford: Oxford University Press, pp.104-131.
- Cinque, G. 2001. "Restructuring" and functional structure. In L. Bruge, (ed.) *University of Venice Working Papers in Linguistics* 11, pp.45-127.
- Culicover, P. W. 1996. On Distinguishing A'-movement. *Linguistic Inquiry* 27, pp.445-463.
- Enc, M. 1991. The Semantics of Specificity. *Linguistic Inquiry* 22, pp.1-25.
- Frank, R. 2005. Phase Theory and Tree Adjoining Grammar. Unpublished Manuscript, Johns Hopkins University, Baltimore.
- Franks, R. and Lavine, J. 2006. Case and word order in Lithuanian. *Journal of Linguistics* 42, pp.239-288.
- Hornstein, N. and Uriagereka, J. 2002. Rejections. In S. J. Epstein and T. D. Seely, (eds.) *Derivations and Explanations in Minimalist Program*. Oxford: Blackwell Publishing, pp.106-132.
- Hornstein, N. 2005. Deriving C-command. Unpublished Manuscript. University of Maryland, College Park.
- Koopman, H. 2003. Inside the Noun in Maasai. In A. Mahajan, (ed.) *Syntax at Sunset* 3. <http://linguistics.ucla.edu/facility/wpl/issues/wpl10.htm>.
- May, R. 1985. *Logical Form: Its Structure and Derivation*. MA: MIT Press.
- McCloskey, J. 2000. Resumption, Successive Cyclicity, and the Locality of Operations. Unpublished Manuscript, University of California, Santa Cruz.
- Nevins, A. and Anand, P. 2003. Some AGREEMENT Matters. In G. Garding and M. Tsujimura, (eds.) *Proceedings of the West Coast Conference on Formal Linguistics* 22, pp.70-383.
- Pesetsky, D. 1989. Language-particular processes and the Earliness Principle. Unpublished Manuscript, MIT, Cambridge, MA.
- Polinsky, M. 2000. Variation in complementation constructions: long-distance agreement in Tsez. In K. Horie, (ed.) *Complementation: Cognition and Function Perspectives*. Philadelphia: John Benjamins, pp.59-90.
- Polinsky, M. and Potsdam E. 2001. Long-Distance Agreement and Topic in Tsez. *Natural Language and Linguistic Theory* 19, pp.583-646.
- Ritter, E. and Rosen, S. T. 2005. Agreement without A-positions: Another look at Algonquian. *Linguistic Inquiry* 36, pp.648-660.
- Wurmbrand, S. 2001. *Infinitives: Restructuring and clause structure*. Berlin/NY: Mouton de Gruyter.
- Wurmbrand, S. 2004. Two types of restructuring: Lexical vs. Functional. *Lingua* 114, pp.991-1014.
- Uriagereka, J. 1999. Multiple spell-out. In S. J. Epstein and N. Hornstein, (eds.) *Working Minimalism*. Cambridge, MA: MIT Press, pp.251-282.